

ALGAE SENSOR

AL SERIES



FEATURES & BENEFITS

- Affordable, real-time screening for algae in source water
- Outputs as algae or chlorophyll a
- Patented technology to provide superior measurement performance
- Operator friendly, low maintenance design
- Quick and simple optical measurements
- Long life LED technology
- Reagent free operation

MUNICIPAL DRINKING WATER

WATER QUALITY
MONITORING
SOLUTIONS

REAL-TIME MONITORING SOLUTION

Algae Sensor

Real Tech's bypass Algae sensor provides an affordable screening tool to monitor and alarm for source water quality changes. Designed with patented technology, this practical sensor measures algae (cells per mL) or chlorophyll a (μg per L) in real time.

Controllers and Accessories

Our innovative modular product platform ensures our clients gain the real-time water quality monitoring system that meets their specific demands and budget. With multiple controller and accessory options available such as automatic chemical cleaning systems that lower maintenance while improving system performance, Real Tech provides a total solution for all of your unique water quality monitoring needs.

Liquid Ai Compatible

Our Liquid Ai data services complement our real-time water quality monitoring systems. Our Remote Monitoring platform is a powerful data management and visualization tool that enables access to data anywhere, anytime.

MEASUREMENT PRINCIPLE

Real Tech's Algae sensor with patented technology uses absorbance of light to measure chlorophyll a, a green pigment found in algae and cyanobacteria that has a natural absorbance peak in the visible light spectrum. An increase in absorbance in this distinct region is directly proportional to an increase in chlorophyll a concentration. Additional wavelengths of visible light are used to compensate for interference such as turbidity (particles). The system then uses the chlorophyll a concentration to estimate algae concentration. This quick and simple screening method gives operators an early warning to prompt further investigation.

REALTECH
INC.



ALGAE SENSOR SPECIFICATIONS

CHARACTERISTIC	TECHNICAL DATA			
	MODEL	AL4050	AL4100	AL4150
Path Length		50 mm	100 mm	150 mm
Parameters		Algae or chlorophyll a		
Range		Depends on model selected. Refer to range chart.		
Units		Algae (cells per mL) or chlorophyll a (µg/L)		
Sampling Time		30 seconds		
Calibration		Factory calibrated. Field adjustment of calibration is possible.		
Cleaning		In-situ chemical cleaning makes cleaning quick and easy. Automatic chemical cleaning is optional.		
Self-Diagnostics		Detection and diagnosis of internal system fault		
Alarms		Dry contact terminals allow for operator configurable alarms for: high and low set points, low lamp output, leaks, system fault, etc.		
Humidity Control		Humidity sensor with large plug-in regenerating desiccant system		
Wavelength		Multiple wavelengths		
Light Source		LED		
Flow Rate		300-1000 mL/min		
Pressure Rating		20 PSI maximum		
Fluid Connections		1/4" OD tube push-in fittings		
Electrical/Comm.		From controller		
Storage Temp.		-20 to 60°C (-4 to 140°F)		
Operating Temp.		0 to 45°C (32 to 113°F)		
Enclosure		NEMA 4X, wall mountable		
Weight		24 lb		
Dimensions		17.75"H x 15.5"W x 6.75"D		
Warranty		2-year limited warranty (Extended care packages available)		
Sensor Upgrades		High Temp. Upgrade II		

* Technical Specifications are subject to change without notice.

DIMENSIONS

The algae sensors is a bypass cabinet instrument installed directly on a wall, railing or system backboard. Sample is supplied to the sensor from either a pressurized source or from an open-channel using an accessory pumping system.

DIMENSIONS FOR ALGAE SENSOR

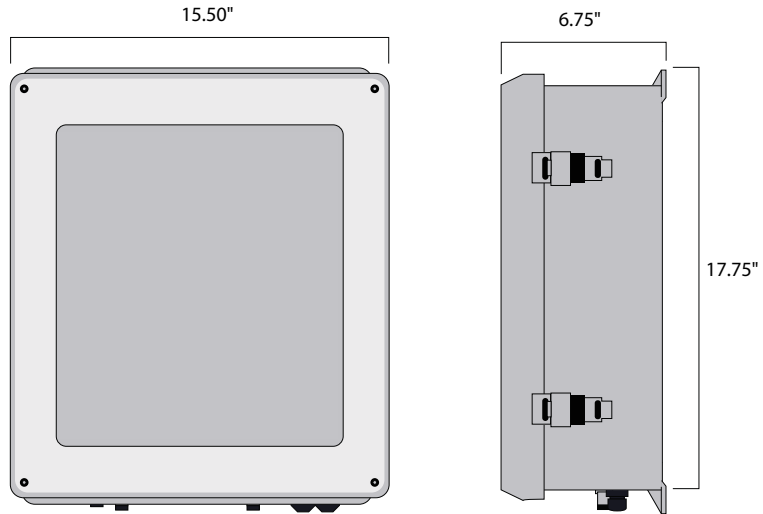

SENSOR MODELS & RANGE

Includes algae sensor, flow cell, calibration bottle and dehumidifier. Controller and accessories sold separately.

MODEL#	PATH LENGTH	ALGAE (cells per mL)	CHLOROPHYLL-A (µg/L)
AL4050	50 mm	75,000 - 15,000,000	37.5 - 7500
AL4100	100 mm	40,000 - 8,000,000	20 - 4000
AL4150	150 mm	30,000 - 6,000,000	15 - 3000

* Stated ranges are approximate, dependent on industry, site and application - contact Real Tech to confirm model selection.

CONTROLLERS

PRODUCT #	NAME	DESCRIPTION
S-169000	Real Controller	Wall mounted controller with 4-line x 20-character back lit LCD display for sensors
S-11TPC	Real Controller Pro	Wall mounted controller with touch panel PC interface (PC inside cabinet model)
S-11TPCD	Real Controller Pro	Wall mounted controller with touch panel PC interface (PC external on door model)

ACCESSORIES

PRODUCT #	NAME	DESCRIPTION
UVT-118010	Real Clean System II	Automatic chemical cleaning system for use with 4000 series models
UVT-129122	Pump Clean System II	Self-priming pump and automatic chemical cleaning for use with 4000 series models
S-1789121	Dual Feed II	Dual feed option includes Digital I/O module for use with controllers

Real Tech Inc.

1150 Champlain Court,
Whitby, Ontario L1N 6K9 Canada
TF: 1.877.779.2888 T: 1.905.665.6888
info@realtechwater.com