

BENZENE PROBE

BZA-X SERIES



FEATURES & BENEFITS

- Affordable real-time benzene monitoring
- Multiple wavelength sensor uses patent-pending technology for superior measurement performance
- Robust submersible probe with titanium housing
- Operator friendly, low maintenance UV LED design
- Reagent free optical measurements
- Simple to install and operate

MUNICIPAL DRINKING WATER
MUNICIPAL WASTEWATER
INDUSTRIAL PROCESS WATER
INDUSTRIAL WASTEWATER

WATER QUALITY
MONITORING
SOLUTIONS

REAL-TIME MONITORING SOLUTION

Benzene Probe

Real Tech's robust Benzene submersible probe provides affordable real-time measurement of benzene changes in water or wastewater. The probe's rugged titanium body is built to withstand harsh environments. Designed to meet the needs of many monitoring applications, the BZA-X series offers multiple path length selections for the desired measurement range.

Controllers and Accessories

Our innovative modular product platform ensures our clients gain the real-time water quality monitoring system that meets their specific demands and budget. With multiple controller and accessory options available such as automatic compressed air cleaning systems that lower maintenance while improving system performance, Real Tech provides a total solution for all of your unique water quality needs.

Liquid Ai Compatible

Our Liquid Ai data services complement our real-time water quality monitoring systems. Calibration Health Monitoring ensures accuracy and reliability is maintained so our clients can have the utmost confidence in their results, while our Remote Monitoring platform enables access to data anywhere, anytime.

MEASUREMENT PRINCIPLE

Real Tech's Benzene probe utilizes patent-pending technology to provide superior measurement performance across multiple wavelengths of light using UV LEDs. Many compounds absorb light in the UV-VIS spectrum, and how much the compounds absorb is directly proportional to their concentration. Compounds that may interfere with benzene measurement are compensated for using additional reference wavelengths. Real Tech's innovative Benzene probe is advancing water and wastewater management.

REALTECH
INC.



BENZENE PROBE SPECIFICATIONS

CHARACTERISTIC

TECHNICAL DATA

MODEL	BZA-X2010	BZA-X2020	BZA-X2040	BZA-X2100
Path Length	1 mm	2 mm	4 mm	10 mm
Parameter	Benzene			
Range	Depends on model selected. Refer to range chart.			
Units	mg/L, ppm, µg/L			
Sampling Time	10 seconds			
Calibration	Factory calibrated. Field adjustment of calibration is possible.			
Cleaning	Automatic compressed air cleaning with optional Real Air Clean Systems			
Self-Diagnostics	Detection and diagnosis of internal system fault			
Alarms	Continuous detection of leaks, lamp output, humidity, temperature and electrical fault			
Humidity Control	Humidity sensor with desiccant pack			
Wavelengths	Multiple wavelengths			
Light Source	UV LED			
Electrical/Comm.	From controller			
Storage Temp.	-20 to 60°C (-4 to 140°F)			
Operating Temp.	0 to 45°C (32 to 113°F)			
Housing Material	Titanium			
Weight	4.6 lb			
Dimensions	15" H x 2.0" Diameter			
Warranty	2-year limited warranty (Extended care packages available)			

* Technical Specifications are subject to change without notice.

DIMENSIONS

The benzene probe is a submersible instrument installed directly in-situ using a mounting kit attached to a tank wall or railing.

DIMENSIONS FOR BENZENE PROBE

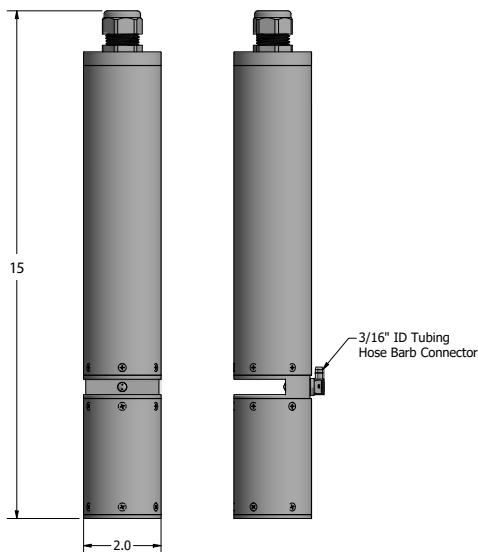

MOUNTING FOR BENZENE PROBE

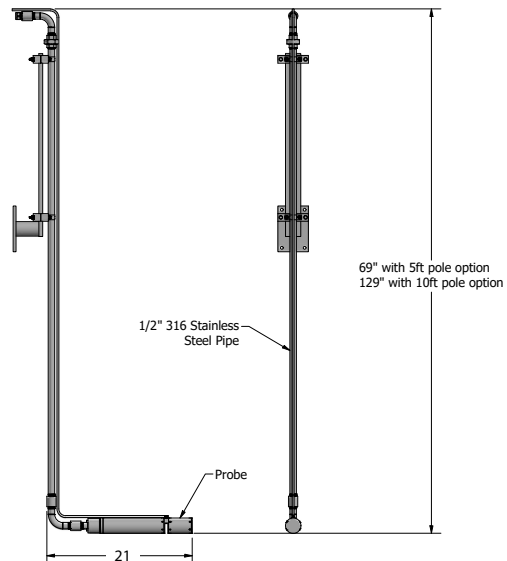

PROBE MODELS & RANGE

Includes benzene probe sensor and 35 feet of communication cable.
Controller, mounting kit and cleaning system sold separately.

MODEL#	PATH LENGTH	BENZENE (mg/L)
BZA-X2010	1 mm	0 - 11,000
BZA-X2020	2 mm	0 - 5500
BZA-X2040	4 mm	0 - 2750
BZA-X2100	10 mm	0 - 1100

* Stated ranges are approximate, dependent on industry, site and application - contact Real Tech to confirm model selection.

CONTROLLERS

PRODUCT #	NAME	DESCRIPTION
S-169000	Real Controller	Wall mounted controller with 4-line x 20-character back lit LCD display
S-11TPC	Real Controller Pro	Wall mounted controller with touch panel PC interface (PC inside cabinet model)
S-11TPCD	Real Controller Pro	Wall mounted controller with touch panel PC interface (PC external on door model)

ACCESSORIES

PRODUCT #	NAME	DESCRIPTION
S-188101	Air Clean System I	Air cleaning valve module requires on-site air (no compressor)
S-188102	Air Clean System II	Low power automatic CO ₂ air cleaning system
S-188103	Air Clean System III	Automatic compressed air cleaning system including compressor
S-219081	Probe Mounting Kit I	Provides secure mounting attachment for titanium probe to a tank wall or open channel wall. No pole included.
S-219082	Probe Mounting Kit II	Provides secure mounting attachment for titanium probe to a tank wall or open channel wall. 5' pole included.
S-219083	Probe Mounting Kit III	Provides secure mounting attachment for titanium probe to a tank wall or open channel wall. 10' pole included.

Real Tech Inc.

1150 Champlain Court,
Whitby, Ontario L1N 6K9 Canada
TF: 1.877.779.2888 T: 1.905.665.6888
info@realtechwater.com

REALTECH
INC.