

HIGH NITRITE PROBE

HN2A-X SERIES



FEATURES & BENEFITS

- Affordable real-time nitrite (NO₂) monitoring
- Ideal for monitoring high levels of nitrite
- Multiple wavelength sensor uses patent-pending technology for superior measurement performance
- Robust submersible probe with titanium housing
- Operator friendly, low-maintenance UV and Visible LED design
- Reagent free optical measurements
- Simple to install and operate

MUNICIPAL DRINKING WATER
MUNICIPAL WASTEWATER
INDUSTRIAL PROCESS WATER
INDUSTRIAL WASTEWATER

WATER QUALITY
MONITORING
SOLUTIONS

REAL-TIME MONITORING SOLUTION

High Nitrite Probe

Real Tech's robust submersible High Nitrite Probe provides affordable real-time measurement of high levels of nitrite (NO₂) in water or wastewater. The probe's rugged titanium body is built to withstand harsh environments. Designed to meet the needs of many monitoring applications, the HN2A-X series offers multiple path length selections for the desired measurement range.

Controllers and Accessories

Our innovative modular product platform ensures our clients gain the real-time water quality monitoring system that meets their specific demands and budget. With multiple controller and accessory options available such as automatic compressed air cleaning systems that lower maintenance while improving system performance, Real Tech provides a total solution for all of your unique water quality monitoring needs.

Liquid Ai Compatible

Our Liquid Ai data services complement our real-time water quality monitoring systems. Our Remote Monitoring platform is a powerful data management and visualization tool that enables access to data anywhere, anytime.

MEASUREMENT PRINCIPLE

Real Tech's High Nitrite Probe utilizes patent-pending technology to provide superior measurement performance across multiple wavelengths of light using UV and Visible LEDs. Many compounds absorb light in the UV-VIS spectrum, and how much the compounds absorb is directly proportional to their concentration. Compounds that may interfere with nitrate and nitrite measurement are compensated for using additional reference wavelengths. Real Tech's innovative High Nitrite Probe is advancing wastewater management.

REALTECH
INC.



HIGH NITRITE PROBE SPECIFICATIONS

CHARACTERISTIC

TECHNICAL DATA

MODEL	HN2A-X2010	HN2A-X2020	HN2A-X2040	HN2A-X2100
Path Length	1 mm	2 mm	4 mm	10 mm
Parameters	Nitrite (NO ₂)			
Range	Depends on model selected. Refer to range chart.			
Accuracy	± 0.5% full scale			
Units	mg/L, ppm			
Sampling Time	10 seconds			
Calibration	Factory calibrated. Field adjustment of calibration is possible.			
Cleaning	Automatic compressed air cleaning with optional Real Air Clean Systems			
Self-Diagnostics	Detection and diagnosis of internal system fault			
Alarms	Continuous detection of leaks, lamp output, humidity, temperature and electrical fault			
Humidity Control	Humidity sensor with desiccant pack			
Wavelength	UV and visible light wavelengths			
Light Source	UV and VIS LED			
Electrical/Comm.	From controller			
Storage Temp.	-20 to 60°C (-4 to 140°F)			
Operating Temp.	0 to 45°C (32 to 113°F)			
Housing Material	Titanium			
Weight	4.6 lb			
Dimensions	15" H x 2.0" Diameter			
Warranty	2-year limited warranty (Extended care packages available)			

* Technical Specifications are subject to change without notice.

DIMENSIONS

The high nitrite probe is a submersible instrument installed directly in-situ using a mounting kit attached to a tank wall or railing.

DIMENSIONS FOR HIGH NITRITE PROBE

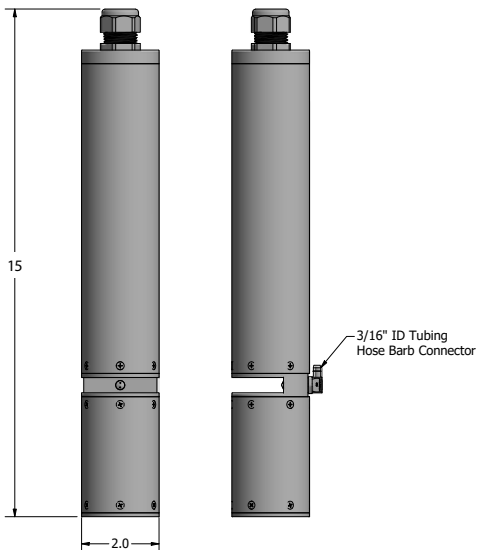

MOUNTING FOR HIGH NITRITE PROBE

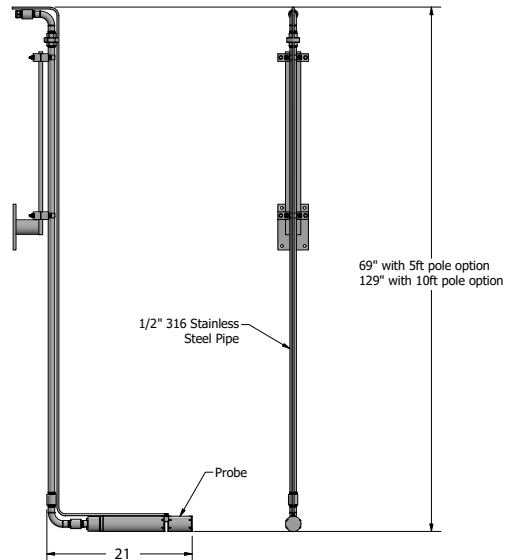

PROBE MODELS & RANGE

Includes high nitrite probe sensor and 35 feet of communication cable.
Controller, mounting kit and cleaning system sold separately.

MODEL#	PATH LENGTH	NO ₂ -N mg/L	NO ₂ mg/L
HN2A-X2010	1 mm	30 - 6000	100 - 20,000
HN2A-X2020	2 mm	15 - 3000	50 - 10,000
HN2A-X2040	4 mm	7.5 - 1500	25 - 5000
HN2A-X2100	10 mm	3 - 600	10 - 2000

* Stated ranges are based on testing in deionized water. Site specific conditions, such as interfering substances in the water, may limit the measuring range and accuracy.
Please contact Real Tech to confirm model selection.

CONTROLLERS

PRODUCT #	NAME	DESCRIPTION
S-169000	Real Controller	Wall mounted controller with 4-line x 20-character back lit LCD display
S-11TPC	Real Controller Pro	Wall mounted controller with touch panel PC interface (PC inside cabinet model)
S-11TPCD	Real Controller Pro	Wall mounted controller with touch panel PC interface (PC external on door model)

ACCESSORIES

PRODUCT #	NAME	DESCRIPTION
S-188101	Air Clean System I	Air cleaning valve module requires on-site air (no compressor)
S-188102	Air Clean System II	Low power automatic CO ₂ air cleaning system
S-188103	Air Clean System III	Automatic compressed air cleaning system including compressor
S-219081	Probe Mounting Kit I	Provides secure mounting attachment for titanium probe to a tank wall or open channel wall. No pole included.
S-219082	Probe Mounting Kit II	Provides secure mounting attachment for titanium probe to a tank wall or open channel wall. 5' pole included.
S-219083	Probe Mounting Kit III	Provides secure mounting attachment for titanium probe to a tank wall or open channel wall. 10' pole included.

Real Tech Inc.

1150 Champlain Court,
Whitby, Ontario L1N 6K9 Canada
TF: 1.877.779.2888 T: 1.905.665.6888
info@realtechwater.com

REALTECH
INC.