

PUMP CLEAN SYSTEMS



FEATURES & BENEFITS

- Saves time and lowers maintenance
- Limits flow cell fouling and enhances performance
- Multipurpose cleaning and pumping system
- User configurable automatic cleaning cycle
- Recapture feature recycles cleaning fluid
- Long life peristaltic pumps

WATER QUALITY
MONITORING
SOLUTIONS

OVERVIEW

For open channel or non pressurized applications where solids are low, the Pump clean system is the ideal choice. The system combines both a sample pumping component and a chemical cleaning component in one. The cleaning frequency is programmable, allowing cleaning cycles to be configured for site specific needs. The automatic cleaning cycles save time and lower maintenance while improving overall operation and accuracy of the instrument.

MODELS

PRODUCT #	NAME	DESCRIPTION
UVT-079121	Pump Clean System I	Self-priming pump and automatic chemical cleaning for use with 2000 and 3000 series models
UVT-129122	Pump Clean System II	Self-priming pump and automatic chemical cleaning for use with 4000 series models

The Pump Clean systems are designed for use with non-pressurized sample water (vertical lift less than 8ft and pumping distance less than 25ft) and minimal solids in sample stream (<10 mg/L TSS).

SPECIFICATIONS

CHARACTERISTIC	TECHNICAL DATA
Cleaning Frequency	User configurable
Cleaning Capacity	1L storage container, cleaning fluid recapture feature reduces fluid replenishment frequency
Max Head Height	8 Feet
Max Horizontal Distance	25 Feet
Alarms	Leak, Cleaning Fluid Low, Cleaning Fluid Empty
Electrical/Communication	From controller/ analyzer
Dimensions	12.0"H x 14.75"W x 7.5"D (Pump Clean I) or 13.75"H x 16.75"W x 7.5"D (Pump Clean II)
Enclosure	NEMA 4, Wall mountable
Fluid Connections	1/4" tube push-in fittings
Storage Temp.	-20 to 60°C (-4 to 140°F)
Operating Temp.	0 to 45°C (32 to 113°F)
Weight	10 lb
Warranty	2-year limited warranty

*Technical Specifications are subject to change without notice.

DIMENSIONS

The Pump Clean systems are installed directly on a wall, railing or system backboard.

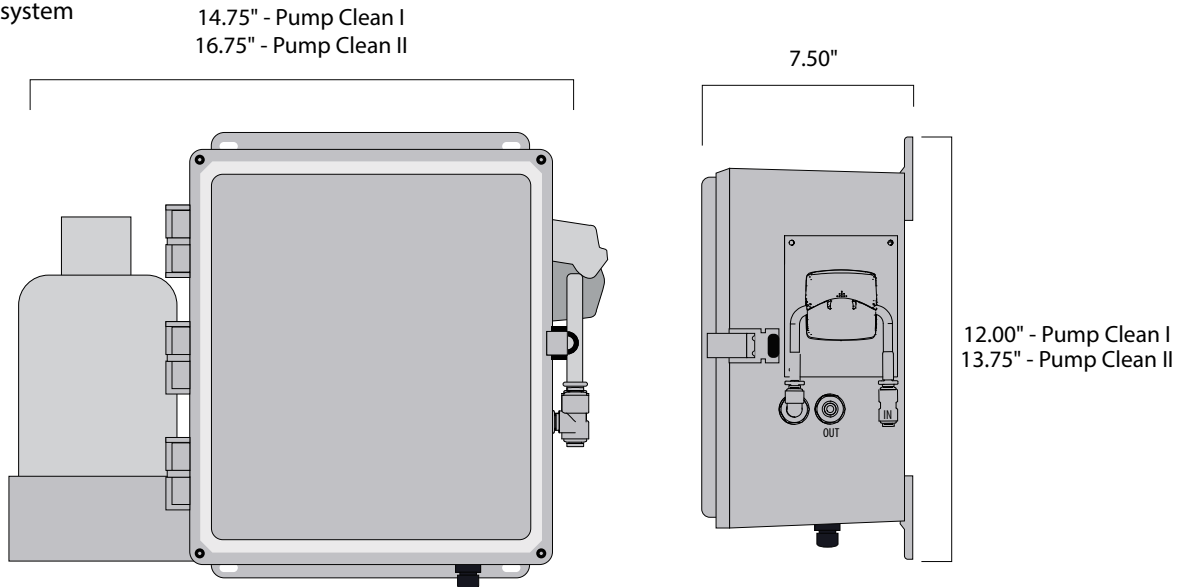

Real Tech Inc.

1150 Champlain Court,
Whitby, Ontario L1N 6K9 Canada
TF: 1.877.779.2888 T: 1.905.665.6888
info@realtechwater.com