

HIGH NITRITE SENSOR

HN2L SERIES



FEATURES & BENEFITS

- Affordable real-time nitrite (NO₂) monitoring
- Ideal for monitoring high levels of nitrite
- Multiple wavelength sensor uses UV LED technology for superior measurement performance
- Bypass style sensor with multiple flow cell selections to meet application demands
- Operator friendly, low-maintenance UV and Visible LED design
- Reagent free optical measurements
- Simple to install and operate

MUNICIPAL DRINKING WATER
MUNICIPAL WASTEWATER
INDUSTRIAL PROCESS WATER
INDUSTRIAL WASTEWATER

WATER QUALITY
MONITORING
SOLUTIONS

REAL-TIME MONITORING SOLUTION

High Nitrite Sensor

Real Tech's bypass High Nitrite Sensor provides affordable real-time measurement of high levels of nitrite in water or wastewater. Designed to meet the needs of many monitoring applications, the HN2L series offers multiple flow cell designs and sensor path length selections to meet the desired measurement range.

Controllers and Accessories

Our innovative modular product platform ensures our clients gain the real-time water quality monitoring system that meets their specific demands and budget. With multiple controller and accessory options available such as automatic chemical cleaning systems that lower maintenance while improving system performance, Real Tech provides a total solution for all of your unique water quality monitoring needs.

Liquid Ai Compatible

Our Liquid Ai data services complement our real-time water quality monitoring systems. Our Remote Monitoring platform is a powerful data management and visualization tool that enables access to data anywhere, anytime.

MEASUREMENT PRINCIPLE

Real Tech's High Nitrite Sensor provides superior measurement performance across multiple wavelengths of light using UV and Visible LEDs. Many compounds absorb light in the UV-VIS spectrum, and how much the compounds absorb is directly proportional to their concentration. Compounds that may interfere with measurement are compensated for using additional reference wavelengths. Real Tech's innovative High Nitrite Sensor is advancing water and wastewater management.

REALTECH
INC.



HIGH NITRITE SENSOR SPECIFICATIONS

CHARACTERISTIC	TECHNICAL DATA		
	1000 series	2000 series	4000 series
Model Series	1000 series	2000 series	4000 series
Path Length	0.5, 1, 2, 4, 10 mm	1, 2, 4, 8 mm	25, 50, 100, 150 mm
Parameters	Nitrite (NO ₂)		
Range	Depends on model selected. Refer to range chart.		
Accuracy	± 0.5% full scale		
Units	mg/L, ppm		
Sampling Time	30 seconds		
Calibration	Factory calibrated. Field adjustment of calibration is possible.		
Cleaning	In-situ chemical cleaning makes cleaning quick and easy. Automatic chemical cleaning is optional.		
Self-Diagnostics	Detection and diagnosis of internal system fault		
Alarms	Dry contact terminals allow for operator configurable alarms for: high and low set points, low lamp output, leaks, system fault, etc.		
Humidity Control	Humidity sensor with large plug-in regenerating desiccant system		
Wavelength	UV and visible light wavelengths		
Light Source	UV LED		
Flow Rate	500-1000 mL/min	300-1000 mL/min	
Pressure Rating	85 PSI maximum	20 PSI maximum	
Fluid Connections	3/8" OD tube push-in fittings	1/4" OD tube push-in fittings	
Sensor Upgrades	Kynar, FEP, Quartz, SS316L, Viton	Kynar, Polyethylene, Quartz, SS 316L, Viton	
Electrical/Comm.	From controller		
Ambient Temp.	0 to 45°C (32 to 113°F)		
Water Temp.	0 to 90°C (32 to 194°F) at 21°C (69.8°F) Ambient temperature		
Enclosure	NEMA 4X, wall mountable		
Weight	22 lb	24 lb	
Dimensions	17"H x 14.25"W x 7.5"D	15.82"H x 13.82"W x 9.00"D	
Warranty	2-year limited warranty (Extended care packages available)		

* Technical Specifications are subject to change without notice.

* Water temperature range based on material compatibility only. Contact Real Tech to verify application.

DIMENSIONS

The High Nitrite Sensor is a bypass cabinet instrument installed directly on a wall, railing or system backboard. Sample is supplied to the sensor from either a pressurized source or from an open-channel using an accessory pumping system.

DIMENSIONS FOR 1000 & 2000 SERIES MODELS

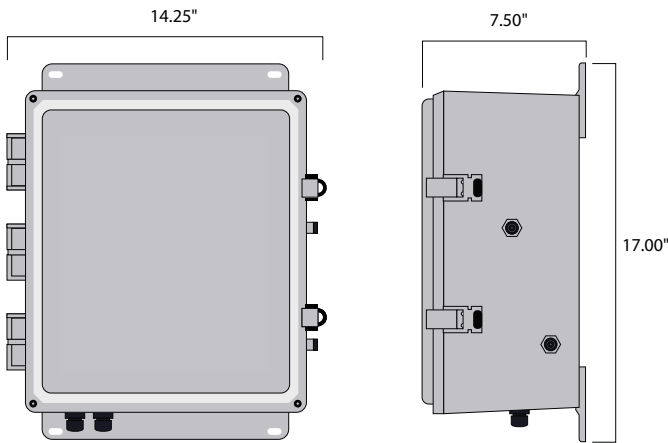

DIMENSIONS FOR 4000 SERIES MODELS

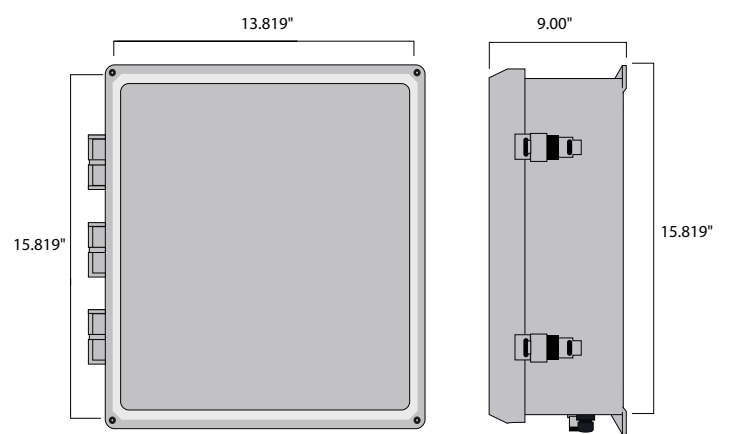

SENSOR SELECTION

MODEL SERIES	DESCRIPTION
1000	Ideal for closed loop, high pressure or high solids wastewater monitoring applications
2000	Ideal for general water monitoring applications
4000	Ideal for high purity water monitoring applications

SENSOR MODELS & RANGE

Includes high nitrite sensor, flow cell, calibration bottle and dehumidifier. Controller and accessories sold separately.

MODEL#	PATH LENGTH	NO ₂ -N mg/L	NO ₂ mg/L
HN2L1005	0.5 mm	60 - 12,000	200 - 40,000
HN2L1010	1 mm	30 - 6000	100 - 20,000
HN2L1020	2 mm	15 - 3000	50 - 10,000
HN2L1040	4 mm	7.5 - 1500	25 - 5000
HN2L1100	10 mm	3 - 600	10 - 2000
HN2L2010	1 mm	30 - 6000	100 - 20,000
HN2L2020	2 mm	15 - 3000	50 - 10,000
HN2L2040	4 mm	7.5 - 1500	25 - 5000
HN2L2080	8 mm	3.75 - 750	12 - 2500
HN2L4025	25 mm	1.2 - 240	4 - 800
HN2L4050	50 mm	0.6 - 120	2 - 400
HN2L4100	100 mm	0.3 - 60	1 - 200
HN2L4150	150 mm	0.2 - 40	0.7 - 130

* Stated ranges are based on testing in deionized water. Site specific conditions, such as interfering substances in the water, may limit the measuring range and accuracy. Please contact Real Tech to confirm model selection.

CONTROLLERS

Controllers include proprietary inputs for Real Tech sensors and accessories.

PRODUCT #	NAME	DESCRIPTION
S--229005	Real Controller Lite	Wall mounted controller with 4-line x 20-character back lit LCD display. Includes modbus RTU (RS485)
S-169000	Real Controller	Wall mounted controller with 4-line x 20-character back lit LCD display. Includes modbus RTU (RS485), 1 channel of 4-20 mA out and digital I/O module
S-11TPC	Real Controller Pro	Wall mounted controller with 12.1" colour LCD touch panel PC interface (PC inside cabinet model). Includes Modbus TCP
S-11TPCD	Real Controller Pro	Wall mounted controller with 12.1" colour LCD touch panel PC interface (PC external on door model). Includes Modbus TCP

ACCESSORIES

PRODUCT #	NAME	DESCRIPTION
UVT-078130	Real Clean System I	Automatic chemical cleaning system for use with 2000 series models
UVT-118010	Real Clean System II	Automatic chemical cleaning system for use with 4000 series models
UVT-079121	Pump Clean System I	Self-priming pump and automatic chemical cleaning for use with 2000 series models
UVT-129122	Pump Clean System II	Self-priming pump and automatic chemical cleaning for use with 4000 series models
S-178121	Dual Feed II	Dual feed option includes Digital I/O module for use with controllers

Real Tech Inc.

1150 Champlain Court,
Whitby, Ontario L1N 6K9 Canada
TF: 1.877.779.2888 T: 1.905.665.6888
info@realtechwater.com

REALTECH
INC.