

MULTI-COLOUR SENSOR

MCL SERIES



FEATURES & BENEFITS

- Affordable real-time multi-colour monitoring
- Multiple wavelength sensor uses LED technology for superior measurement performance
- Wastewater to high purity measurement ranges
- Bypass style sensor with multiple flow cell selections to meet application demands
- Operator friendly, low maintenance LED design
- Reagent free optical measurements
- In accordance with ISO7887:2011 Method B
- Simple to install and operate

MUNICIPAL DRINKING WATER
MUNICIPAL WASTEWATER
INDUSTRIAL PROCESS WATER
INDUSTRIAL WASTEWATER

WATER QUALITY
MONITORING
SOLUTIONS

REAL-TIME MONITORING SOLUTION

Multi-Colour Sensor

Real Tech's bypass Multi-Colour Sensor provides affordable real-time measurement of multiple colours in water or wastewater. Designed to meet the needs of many monitoring applications, the MCL series offers multiple flow cell designs and sensor path length selections to meet the desired measurement range.

Controllers and Accessories

Our innovative modular product platform ensures our clients gain the real-time water quality monitoring system that meets their specific demands and budget. With multiple controller and accessory options available such as automatic chemical cleaning systems that lower maintenance while improving system performance, Real Tech provides a total solution for all of your unique water quality monitoring needs.

Liquid Ai Compatible

Our Liquid Ai data services complement our real-time water quality monitoring systems. Our Remote Monitoring platform is a powerful data management and visualization tool that enables access to data anywhere, anytime.

MEASUREMENT PRINCIPLE

Real Tech's Multi-Colour Sensor provides superior measurement performance across multiple wavelengths of light using LEDs. The sensor measures multiple colours in the water in accordance with ISO7887:2011 Method B. Compounds that may interfere with colour measurement, such as particles, are compensated for using an additional reference wavelength. Real Tech's multi-colour sensor is advancing water and wastewater management.

REALTECH
INC.



MULTI-COLOUR SENSOR SPECIFICATIONS

CHARACTERISTIC	TECHNICAL DATA		
Model Series	1000 series	2000 series	4000 series
Path Length	0.5, 1, 2, 4, 10 mm	1, 2, 4, 8 mm	25, 50, 100, 150 mm
Parameters	Colour		
Range	Depends on model selected. Refer to range chart.		
Accuracy	± 0.5% full scale		
Units	1/m		
Sampling Time	30 seconds		
Calibration	Factory calibrated. Field adjustment of calibration is possible.		
Cleaning	In-situ chemical cleaning makes cleaning quick and easy. Automatic chemical cleaning is optional.		
Self-Diagnostics	Detection and diagnosis of internal system fault		
Alarms	Dry contact terminals allow for operator configurable alarms for: high and low set points, low lamp output, leaks, system fault, etc.		
Humidity Control	Humidity sensor with large plug-in regenerating desiccant system		
Wavelengths	Visible (VIS)		
Light Source	LED		
Flow Rate	500-1000 mL/min	300-1000 mL/min	
Pressure Rating	85 PSI maximum	20 PSI maximum	
Fluid Connections	3/8" OD tube push-in fittings	1/4" OD tube push-in fittings	
Wetted Materials	Kynar, FEP, Quartz, SS316L, Viton	Kynar, Polyethylene, Quartz, SS 316L, Viton	
Electrical/Comm.	From controller		
Ambient Temp.	0 to 45°C (32 to 113°F)		
Water Temp.	0 to 90°C (32 to 194°F) at 21°C (69.8°F) Ambient temperature		
Enclosure	NEMA 4X, wall mountable		
Weight	22 lb	24 lb	
Dimensions	17"H x 14.25"W x 7.5"D	15.82"H x 13.82"W x 9.00"D	
Warranty	2-year limited warranty (Extended care packages available)		

* Technical Specifications are subject to change without notice.

* Water temperature range based on material compatibility only. Contact Real Tech to verify application.

DIMENSIONS

The multi-colour sensor is a bypass cabinet instrument installed directly on a wall, railing or system backboard. Sample is supplied to the sensor from either a pressurized source or from an open-channel using an accessory pumping system.

DIMENSIONS FOR 1000 & 2000 SERIES MODELS

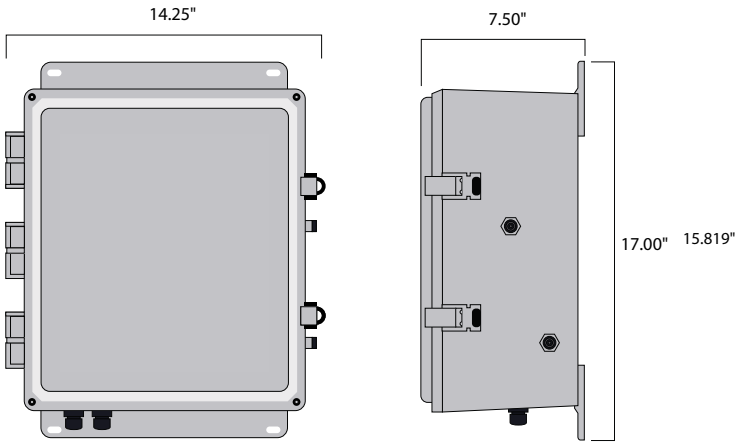

DIMENSIONS FOR 4000 SERIES MODELS

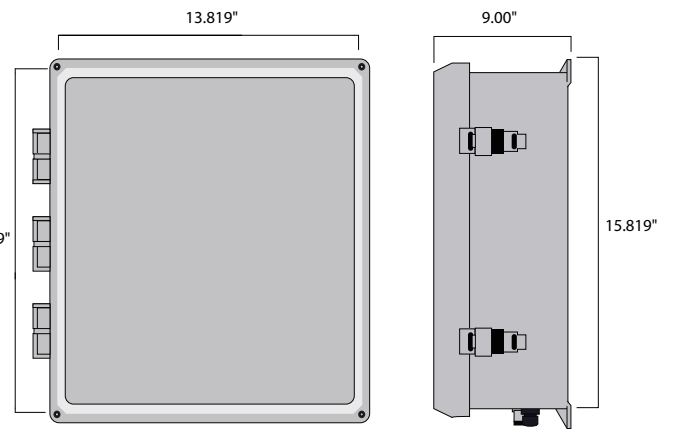

SENSOR SELECTION

MODEL SERIES	DESCRIPTION
1000	Ideal for closed loop, high pressure or high solids wastewater monitoring applications
2000	Ideal for general water monitoring applications
4000	Ideal for high purity water monitoring applications

SENSOR MODELS & RANGE

Includes multi-colour sensor, flow cell, calibration bottle and dehumidifier. Controller and accessories sold separately.

MODEL#	PATH LENGTH	COLOUR (1/m)
MCL1005	0.5 mm	10 - 2000
MCL1010	1 mm	5 - 1000
MCL1020	2 mm	2.5 - 500
MCL1040	4 mm	1.2 - 250
MCL1100	10 mm	0.5 - 100
MCL2010	1 mm	5 - 1000
MCL2020	2 mm	2.5 - 500
MCL2040	4 mm	1.2 - 250
MCL2080	8 mm	0.6 - 125
MCL4025	25 mm	0.2 - 40
MCL4050	50 mm	0.1 - 20
MCL4100	100 mm	0.05 - 10
MCL4150	150 mm	0.03 - 7

* Stated ranges are based on testing in deionized water. Interfering substances that may be present in the water may reduce the upper end of the measuring range. Please contact Real Tech to confirm model selection.

CONTROLLERS

Controllers include proprietary inputs for Real Tech sensors and accessories.

PRODUCT #	NAME	DESCRIPTION
S--229005	Real Controller Lite	Wall mounted controller with 4-line x 20-character back lit LCD display. Includes modbus RTU (RS485)
S-169000	Real Controller	Wall mounted controller with 4-line x 20-character back lit LCD display. Includes modbus RTU (RS485), 1 channel of 4-20 mA out and digital I/O module
S-11TPC	Real Controller Pro	Wall mounted controller with 12.1" colour LCD touch panel PC interface (PC inside cabinet model). Includes Modbus TCP
S-11TPCD	Real Controller Pro	Wall mounted controller with 12.1" colour LCD touch panel PC interface (PC external on door model). Includes Modbus TCP

ACCESSORIES

PRODUCT #	NAME	DESCRIPTION
UVT-078130	Real Clean System I	Automatic chemical cleaning system for use with 2000 series models
UVT-118010	Real Clean System II	Automatic chemical cleaning system for use with 4000 series models
S-178121	Dual Feed II	Dual feed option includes Digital I/O module for use with controllers

Real Tech Inc.

1150 Champlain Court,
Whitby, Ontario L1N 6K9 Canada
TF: 1.877.779.2888 T: 1.905.665.6888
info@realtechwater.com

REALTECH
INC.