

# OZONE PROBE

O3A SERIES

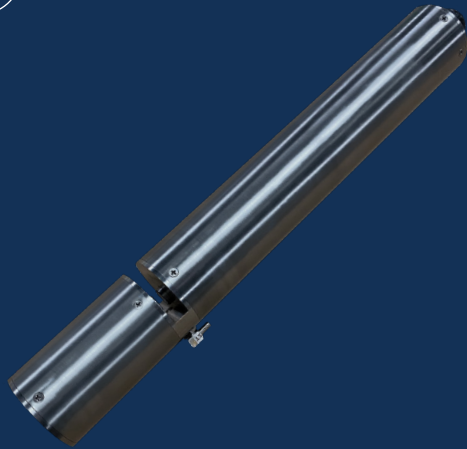

## FEATURES & BENEFITS

- Affordable real-time ozone (O<sub>3</sub>) monitoring
- Multiple wavelength sensor uses patent-pending technology for superior measurement performance
- Robust submersible probe with titanium or stainless steel housing
- Operator friendly, low maintenance UV LED design
- Reagent free optical measurements
- Simple to install and operate

MUNICIPAL WASTEWATER  
INDUSTRIAL WASTEWATER

WATER QUALITY  
MONITORING  
SOLUTIONS

## REAL-TIME MONITORING SOLUTION

### Ozone Probe

Real Tech's robust Ozone submersible probe provides affordable real-time measurement of ozone (O<sub>3</sub>) in water or wastewater. The probe's rugged body is built to withstand harsh environments, with titanium or stainless steel options. Designed to meet the needs of many monitoring applications, the O3A series offers multiple path length selections for the desired measurement range.

### Controllers and Accessories

Our innovative modular product platform ensures our clients gain the real-time water quality monitoring system that meets their specific demands and budget. With multiple controller and accessory options available such as automatic compressed air cleaning systems that lower maintenance while improving system performance, Real Tech provides a total solution for all of your unique water quality needs.

### Liquid Ai Compatible

Our Liquid Ai data services complement our real-time water quality monitoring systems. Our Remote Monitoring platform is a powerful data management and visualization tool that enables access to data anywhere, anytime.

## MEASUREMENT PRINCIPLE

Real Tech's Ozone probe utilizes patent-pending technology to provide superior measurement performance across multiple wavelengths of light using UV LEDs. Many compounds absorb light in the UV-VIS spectrum, and how much the compounds absorb is directly proportional to their concentration. Compounds that may interfere with ozone measurement are compensated for using additional reference wavelengths. Real Tech's innovative Ozone probe is advancing wastewater management.

**REALTECH**  
INC.

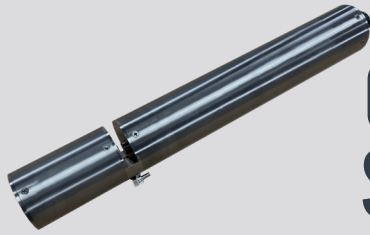

# OZONE PROBE SPECIFICATIONS

CHARACTERISTIC	TECHNICAL DATA	
Model	O3A-X	O3A-S
Path Length	1, 2, 4, 10 mm	
Parameters	Ozone (O <sub>3</sub> )	
Range	Depends on model selected. Refer to range chart.	
Accuracy	± 1% full scale	
Units	mg/L	
Sampling Time	10 seconds	
Calibration	Factory calibrated. Field adjustment of calibration is possible.	
Cleaning	Automatic compressed air or pressurized water cleaning with optional Probe Clean System	
Self-Diagnostics	Detection and diagnosis of internal system fault	
Alarms	Continuous detection of leaks, lamp output, humidity, temperature and electrical fault	
Humidity Control	Humidity sensor with desiccant pack	
Wavelengths	Multiple wavelengths	
Light Source	UV LED	
Electrical/Comm.	From controller	
Pressure Rating	15 PSI	
Operating Temp.	0 to 45°C (32 to 113°F)	
Housing Material	Titanium (Grade 2)	Stainless steel (SS 316)
Wetted Materials	Titanium, Epoxy, Sapphire, SS 316, Viton	Epoxy, Sapphire, SS 316, Viton
Weight	1.5kg (3.31lb)**	2.5kg (5.25lb)**
Ingress Protection Type	IPX8	
Dimensions	15" H x 2.0" Diameter	
Warranty	2-year limited warranty (Extended care packages available)	

\* Technical Specifications are subject to change without notice.

\* Operating (water) temperature absolute maximum 55°C (131°F). Instrument performance reduced when operating outside recommended operating range. Contact Real Tech to verify application.

\*\* Weight does not include cable. Cable weight: 0.70kg (1.55lb).

## DIMENSIONS

The ozone probe is a submersible instrument installed directly in-situ using a pole mounting kit or chain mount.

### DIMENSIONS FOR OZONE PROBE

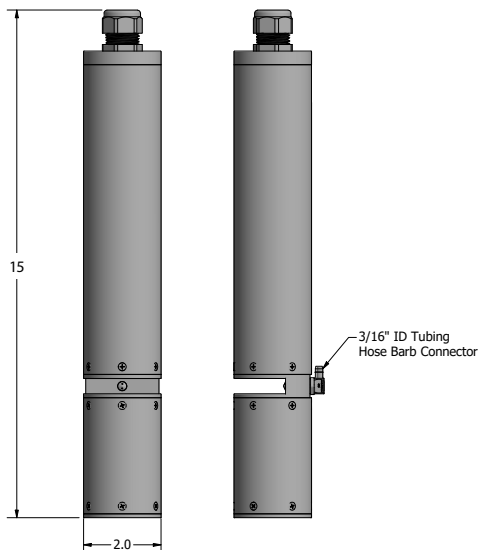

### MOUNTING FOR OZONE PROBE

#### Pole mount

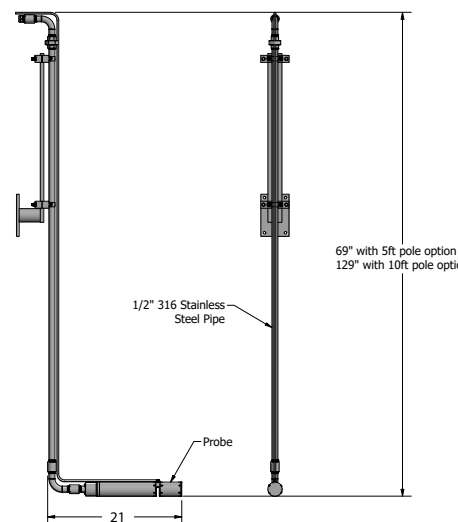

#### Chain mount



## PROBE MODELS & RANGE

Includes titanium (-X) or stainless steel (-S) ozone probe sensor and 35 feet of communication cable. Controller, mounting kit and cleaning system sold separately.

MODEL#	PATH LENGTH	OZONE (mg/L)
O3A-X2010 / O3A-S2010	1 mm	0 - 128
O3A-X2020 / O3A-S2020	2 mm	0 - 64
O3A-X2040 / O3A-S2040	4 mm	0 - 32
O3A-X2100 / O3A-S2100	10 mm	0 - 12.8

\* Stated ranges are approximate, dependent on industry, site and application - contact Real Tech to confirm model selection.

## CONTROLLERS

Controllers include proprietary inputs for Real Tech sensors and accessories.

PRODUCT #	NAME	DESCRIPTION
S-229005	Real Controller Lite	Wall mounted controller with 4-line x 20-character back lit LCD display. Includes modbus RTU (RS485)
S-169000	Real Controller	Wall mounted controller with 4-line x 20-character back lit LCD display. Includes modbus RTU (RS485), 1 channel of 4-20 mA out and digital I/O module
S-11TPC	Real Controller Pro	Wall mounted controller with 12.1" colour LCD touch panel PC interface (PC inside cabinet model). Includes Modbus TCP
S-11TPCD	Real Controller Pro	Wall mounted controller with 12.1" colour LCD touch panel PC interface (PC external on door model). Includes Modbus TCP

## ACCESSORIES

PRODUCT #	NAME	DESCRIPTION
S-228070	Probe Clean System	Cleaning valve module requires on-site compressed air or pressured water for automatic probe cleaning
S-228080	Compressed Air System	Compressor for air cleaning when compressed air not available on-site
S-219081	Probe Mounting Kit I	Provides secure mounting attachment for titanium or stainless steel probe to a tank wall or open channel wall. No pole included.
S-219082	Probe Mounting Kit II	Provides secure mounting attachment for titanium or stainless steel probe to a tank wall or open channel wall. 5' pole included.
S-219083	Probe Mounting Kit III	Provides secure mounting attachment for titanium or stainless steel probe to a tank wall or open channel wall. 10' pole included.
S-229085	Chain Mount	Stainless steel chain for mounting probe in open channel

### Real Tech Inc.

1150 Champlain Court,  
Whitby, Ontario L1N 6K9 Canada  
TF: 1.877.779.2888 T: 1.905.665.6888  
info@realtechwater.com

**REALTECH**  
INC.