

# SPECTRUM SENSOR

WATER QUALITY  
MONITORING  
SOLUTIONS

GL SERIES

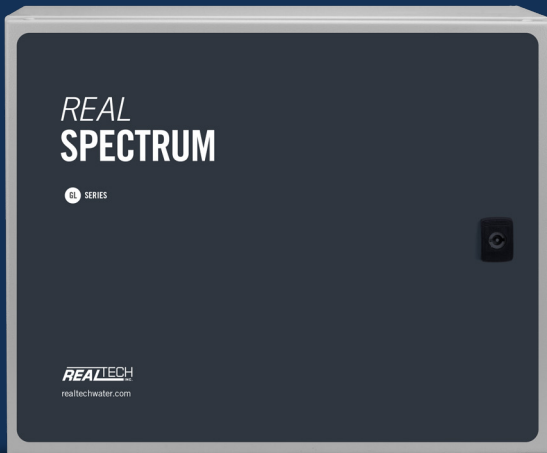

## FEATURES & BENEFITS

- Reliable real-time water quality information
- Multiple wavelength UV-VIS sensor (200-750 nm)
- Wastewater to high purity measurement ranges
- Bypass style sensor with multiple flow cell selections to meet application demands
- Simple optical measurements, no reagents
- Multiple parameter configuration available
- Parameters include BOD, COD, TOC, DOC, UV254, UVT, TSS, nitrate, nitrite, permanganate, colour and many more

## REAL-TIME MONITORING SOLUTION

### Spectrum Sensor

Real Tech's bypass Spectrum sensor provides real-time measurement of organic matter, nitrate and other compounds in water or wastewater. Designed to meet the needs of many monitoring applications, the GL series offers multiple flow cell designs and sensor path length selections for the desired measurement range.

### Controllers And Accessories

Our innovative modular product platform ensures our clients gain the real-time water quality monitoring system that meets their specific demands and budget. With multiple controller and accessory options available such as automatic chemical cleaning systems that lower maintenance while improving system performance, Real Tech provides a total solution for all of your unique water quality needs.

### Liquid Ai Compatible

Our Liquid Ai data services complement our real-time water quality monitoring systems. Calibration Health Monitoring ensures accuracy and reliability are maintained so our clients can have the utmost confidence in their results, while our Remote Monitoring platform enables access to data anywhere, anytime.

## MEASUREMENT PRINCIPLE

Real Tech's Spectrum sensor utilizes UV-VIS light for measurement, continuously scanning the water with multiple wavelength, configurable up to 40 between 200-750 nm. The sensor benefits from Real Tech's innovative Split-Sense Pro technology that compensates for lamp drift and fluctuations, providing an accurate and stable output overtime. GL series spectrum sensor parameters include BOD, COD, TOC, DOC, UV254, UVT, TSS, NO<sub>3</sub>, NO<sub>2</sub>, colour, permanganate, contaminant alarms, spectral fingerprint and custom alarms, dependant on application and industry.

MUNICIPAL DRINKING WATER  
MUNICIPAL WASTEWATER  
INDUSTRIAL PROCESS WATER  
INDUSTRIAL WASTEWATER

**REALTECH**  
INC.



# SPECTRUM SENSOR SPECIFICATIONS

CHARACTERISTIC	TECHNICAL DATA		
Model Series	1000 series	2000 series	4000 series
Path Length	0.5, 1, 2, 4, 10 mm	1, 2, 4, 8 mm	25, 50, 150 mm
Parameters	BOD, COD, TOC, DOC, UV254, UVT, TSS, nitrate, nitrite, permanganate, colour, contaminant alarms, spectral fingerprint, custom alarm		
Range	Depends on model selected. Refer to range chart on next page.		
Units	Parameter specific (mg/L, cm <sup>-1</sup> , % or PCU)		
Sampling Time	1 minute		
Calibration	Factory calibrated. Field adjustment of calibration is possible.		
Cleaning	In-situ chemical cleaning makes cleaning quick and easy. Automatic chemical cleaning is optional.		
Self-Diagnostics	Detection and diagnosis of internal system fault		
Alarms	Dry contact terminals allow for operator configurable alarms for: high and low set points, low lamp output, leak detect, system fault, etc.		
Humidity Control	Humidity sensor with large plug-in regenerating desiccant system		
Wavelengths	Configurable up to 40 wavelength between 200-750 nm		
Light Source	Xenon Flash Lamp		
Lamp Life	2-5 years		
Flow Rate	500-1000 mL/min	300-1000 mL/min	
Pressure Rating	85 PSI maximum	20 PSI maximum	
Fluid Connections	3/8" tube push-in fittings	1/4" tube push-in fittings	
Wetted Materials	Kynar, FEP, Quartz, SS316L, Viton	Kynar, Polyethylene, Quartz, SS 316L, Viton	
Electrical/Comm.	From controller		
Ambient Temp.	0 to 45°C (32 to 113°F)		
Water Temp.	0 to 35°C (32 to 95°F) at 21°C (69.8°F) Ambient temperature		
Enclosure	NEMA 4, wall mountable		
Weight	44 lb		
Dimensions	19.0"H x 20.5"W x 9.0"D		
Warranty	2-year limited warranty (Extended care packages available)		

\* Technical Specifications are subject to change without notice.

\* Water temperature range based on material compatibility only. Contact Real Tech to verify application.

## DIMENSIONS

The spectrum sensor is a bypass cabinet instrument installed directly on a wall, railing or system backboard. Sample is supplied to the sensor from either a pressurized source or from an open-channel using an accessory pumping system.

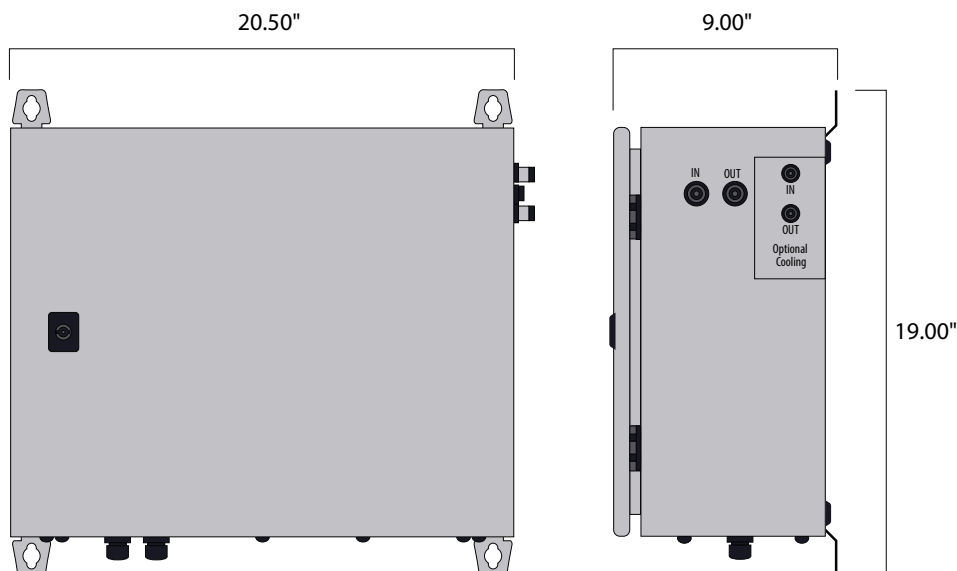

## SENSOR SELECTION

MODEL SERIES	DESCRIPTION
1000	Ideal for closed loop, high pressure or high solids wastewater monitoring applications
2000	Ideal for general water monitoring applications
4000	Ideal for high purity water monitoring applications

## SENSOR MODELS & RANGE

Includes UV-VIS spectrum sensor, flow cell, calibration bottle and dehumidifier. Controller and accessories sold separately.

MODEL#	PATH LENGTH	BOD (mg/L)	COD (mg/L)	TOC/DOC (mg/L)	UV254 (cm <sup>-1</sup> )	COLOUR (PCU)	NO <sub>3</sub> <sup>-</sup> N (mg/L)	NO <sub>3</sub> (mg/L)	NO <sub>2</sub> <sup>-</sup> N (mg/L)
GL1005	0.5 mm	0 - 3000	0 - 6000	0 - 1600	0 - 40	0 - 20,000	0 - 100	0 - 440	0 - 100
GL1010	1 mm	0 - 1500	0 - 3000	0 - 800	0 - 20	0 - 10,000	0 - 50	0 - 220	0 - 50
GL1020	2 mm	0 - 750	0 - 1500	0 - 400	0 - 10	0 - 5000	0 - 25	0 - 110	0 - 25
GL1040	4 mm	0 - 375	0 - 750	0 - 200	0 - 5	0 - 2500	0 - 12.5	0 - 55	0 - 12.5
GL1080	10 mm	0 - 150	0 - 300	0 - 80	0 - 2	0 - 1000	0 - 5	0 - 22	0 - 5
GL2010	1 mm	0 - 1500	0 - 3000	0 - 800	0 - 20	0 - 10,000	0 - 50	0 - 220	0 - 50
GL2020	2 mm	0 - 750	0 - 1500	0 - 400	0 - 10	0 - 5000	0 - 25	0 - 110	0 - 25
GL2040	4 mm	0 - 375	0 - 750	0 - 200	0 - 5	0 - 2500	0 - 12.5	0 - 55	0 - 12.5
GL2080	8 mm	0 - 187	0 - 375	0 - 100	0 - 2.5	0 - 1250	0 - 6.25	0 - 27.5	0 - 6.25
GL4025	25 mm	0 - 60	0 - 120	0 - 32	0 - 0.8	0 - 400	0 - 2	0 - 8.8	0 - 2
GL4050	50 mm	0 - 30	0 - 60	0 - 16	0 - 0.4	0 - 200	0 - 1	0 - 4.4	0 - 1
GL4150	150 mm	0 - 10	0 - 20	0 - 5.3	0 - 0.13	0 - 33	0 - 0.33	0 - 1.45	0 - 0.33

\* Stated ranges are approximate, dependent on industry, site and application - contact Real Tech to confirm model selection

\* Range for TSS, permanganate, contaminant alarms, spectral fingerprint, and custom alarms are site specific, contact Real Tech for details

\* Higher maximum range possible with use of Dilution System option

## CONTROLLERS

PRODUCT #	NAME	DESCRIPTION
S-11TPC	Real Controller Pro	Wall mounted controller with touch panel PC interface (PC inside cabinet model)
S-11TPCD	Real Controller Pro	Wall mounted controller with touch panel PC interface (PC external on door model)

## ACCESSORIES

PRODUCT #	NAME	DESCRIPTION
UVT-078130	Real Clean System I	Automatic chemical cleaning system for use with 2000 series models
UVT-118010	Real Clean System II	Automatic chemical cleaning system for use with 4000 series models
UVT-079121	Pump Clean System I	Self-priming pump and automatic chemical cleaning for use with 2000 series models
UVT-129122	Pump Clean System II	Self-priming pump and automatic chemical cleaning for use with 4000 series models
S-229035	Pump Clean Pro System (pressurized)	For high solids sample water, automatic chemical cleaning and pumping system for up to 25' vertical lift or 100' horizontal in pressurized installation (no air compressor)
S-229036	Pump Clean Pro System (non-pressurized)	For high solids sample water, automatic chemical cleaning and pumping system for up to 25' vertical lift or 100' horizontal in non-pressurized/ open channel installation (no air compressor)
S-178121	Dual Feed II	Dual feed option includes Digital I/O module for use with controllers

## BACKBOARDS & ASSEMBLY

Pre-wired and plumbed solution assembled and mounted on backboard with or without stand.

PRODUCT #	DESCRIPTION
S-169033	46" x 46" Industrial grade black plastic mounting backboard and assembly
S-179034	24" x 60" Industrial grade black plastic mounting backboard and assembly
S-179036	46" x 46" Industrial grade black plastic mounting backboard with stand and assembly
S-179035	24" x 60" Industrial grade black plastic mounting backboard with stand and assembly

### Real Tech Inc.

1150 Champlain Court,  
Whitby, Ontario L1N 6K9 Canada  
TF: 1.877.779.2888 T: 1.905.665.6888  
info@realtechwater.com

